

ROHS COMPLIANT

DESCRIPTION CONTROL			
REV	DESC	DATE	APP
A	FIRST RELEASE	2011/05/05	

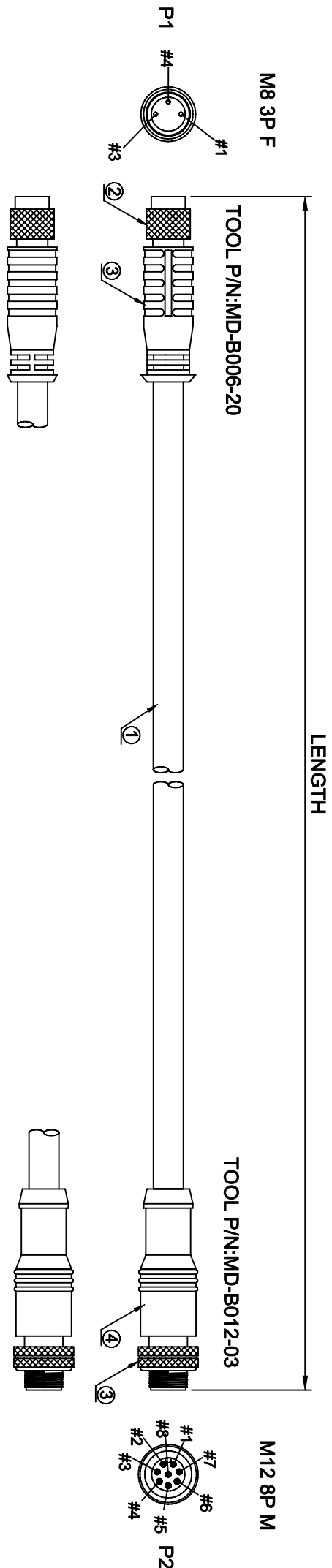

PIN ASSIGNMENT

NOTES:
 1. PIN ASSIGNMENT SEE TO WIRE LIST.
 2. ELECTRICAL TEST CONDITION:
 (a). 100%OPEN,SHORT & MISWIRE TEST,
 (b). INSULATOR RESISTANCE:20 Mohm MIN,
 DC 300V 0.01~0.03sec.
 (c). CONTACT RESISTANCE:3 ohm MAX.

M8 3P F M12 8P M

1 _____ 1
 3 _____ 3
 4 _____ 4
 SHELL _____ SHELL

PART NUMBER	LENGTH
M12 8P M TO M8 3P F CABLE-0.6M	600±25
M12 8P M TO M8 3P F CABLE 1.0M	1000±30
M12 8P M TO M8 3P F CABLE-2.0M	2000±30
M12 8P M TO M8 3P F CABLE-5.0M	5000±50

ITEM	QTY	PART NUMBER	DESCRIPTION
4		G0107	ALL CONNECTORS OVERMOLD BLACK PA.
3	1		M12 8PIN MALE, BALCK INSULATOR,SOLDER TYPE, WITH SHELL.
2	1		M8 3PIN FEMALE, BALCK INSULATOR,SOLDER TYPE, WITH SHELL.
1	1		24AWG*8C+AD, OD:4.5MM, BLACK PVC JACKET, UI2464.

UNIT	mm	Projection	Scale	1:1	SECCON	Seconn International Enterprise Co., Ltd.
DRAWN	Yi Jialu	SCALE	1:1			TITLE
CHECK,BY	Caoyiwei	REV	A			M12 8P M TO M8 3P F CABLE XM LENGTH
APP,BY	Wu. Shuang	DATE	2011/05/05			TOLERANCES
DWG NO.	SE-S-0022					X. = ± .X = ± .XX = ± .XXX = ±
PART NO.	M12 8P M TO M8 3P F CABLE-XM	SHEET	1/1	SIZE		A4