

RoHS COMPLIANT

DESCRIPTION CONTROL			
REV	DESC	DATE	APP
A	FIRST RELEASE	2013/02/27	

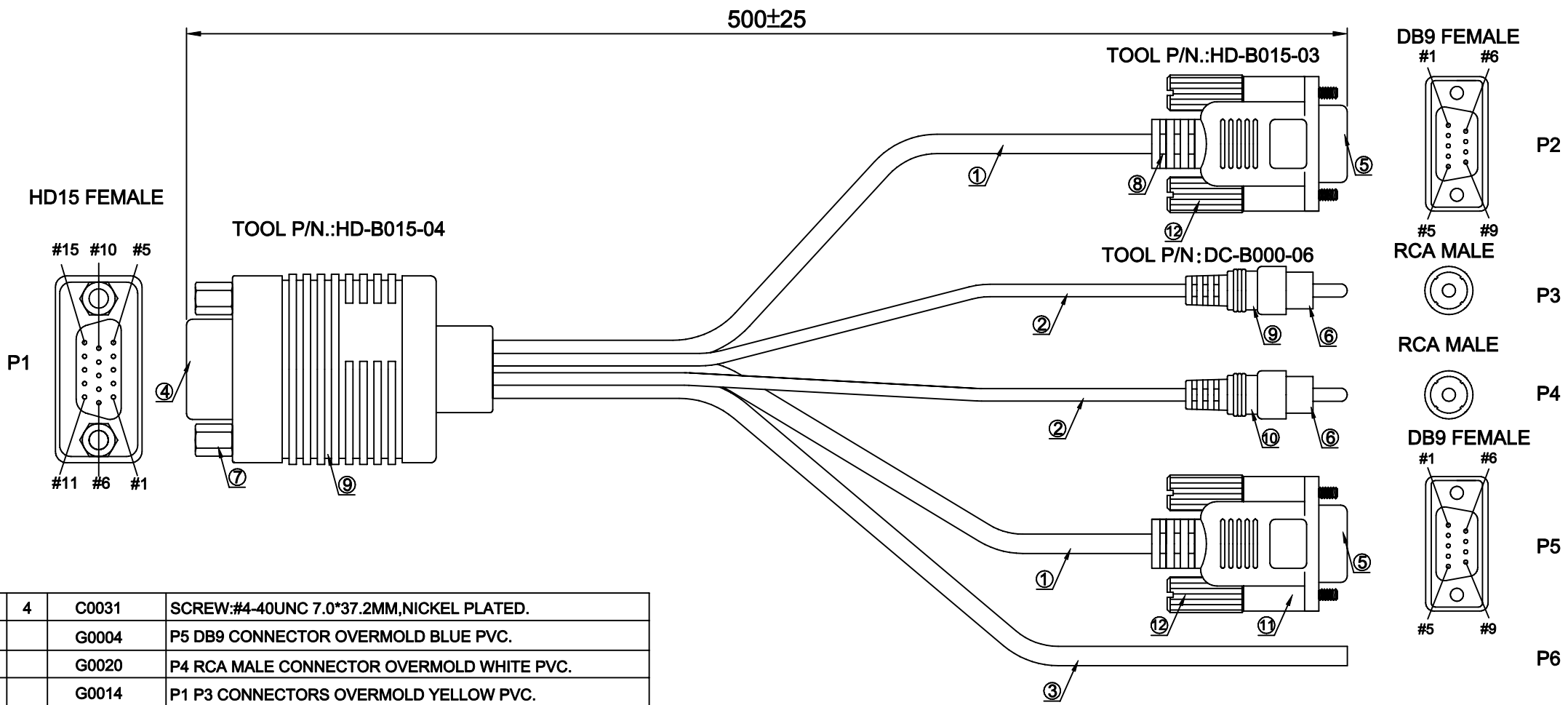

12	4	C0031	SCREW:#4-40UNC 7.0*37.2MM,NICKEL PLATED.
11		G0004	P5 DB9 CONNECTOR OVERMOLD BLUE PVC.
10		G0020	P4 RCA MALE CONNECTOR OVERMOLD WHITE PVC.
9		G0014	P1 P3 CONNECTORS OVERMOLD YELLOW PVC.
8		G0001	P2 DB9 CONNECTOR OVERMOLD BLACK PVC.
7	2	C0099	SCREW:#4-40UNC 4.75*9.0MM NICKEL PLATED.
6	2	A0194	RCA MALE SOLDER TYPE,WHITE INSULATOR .
5	2	A0010	DB9 FEMALE SOLDER TYPE,BLACK INSULATOR.
4	1	A0208	HD15 FEMALE SOLDER TYPE,BLACK INSULATOR,BACK NUT.
3	1		UL2725 22AWG*3C OD:3.8MM BLACK PVC JACKET.
2	2	E0080	UL1354 28AWG*1COAX OD:2.5MM BLACK PVC JACKET.
1	2	E0812	UL2464 28AWG*3C+DRAIN+AM OD:3.8MM BLACK PVC JACKET.
ITEM	QTY	PART NUMBER	DESCRIPTION

UNIT	mm	Projection			Seconn International Enterprise Co., Ltd.		
DRAWN	<i>Yi jialu</i>	SCALE	FREE	TITLE			
CHECK, BY	<i>Bao jianwei</i>	REV	A	HD15 F/2*DB9 F+2*RCA M+OPEN			
APP, BY	<i>Mr. Huang</i>	DATE	2013/02/27	TOLERANCES			
DWG NO.	SE-S-0071			X.= ±	.X= ±	.XX= ±	.XXX= ±
PART NO.		SHEET	1/2	SIZE	A4		

RoHS COMPLIANT

DESCRIPTION CONTROL			
REV	DESC	DATE	APP
A	FIRST RELEASE	2013/02/27	

PIN ASSIGNMENT

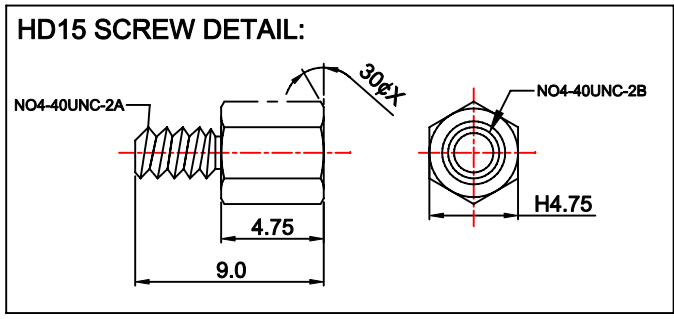
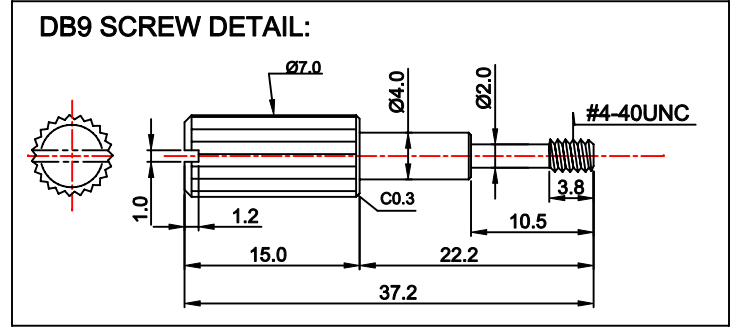
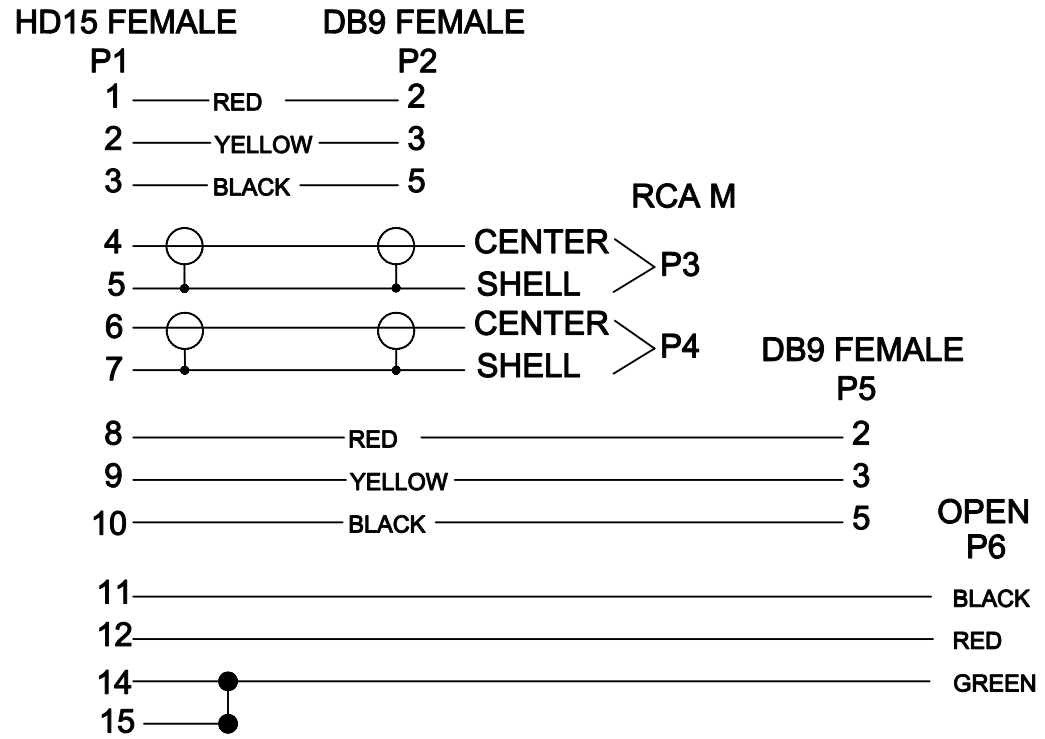

- NOTES:**
- PIN ASSIGNMENT SEE TO WIRE LIST.
 - ELECTRICAL TEST CONDITION:
 - 100%OPEN,SHORT & MISWIRE TEST,
 - INSULATOR RESISTANCE:20 Mohm MIN. DC 300V 0.01sec.
 - CONTACT RESISTANCE:3 ohm MAX.

UNIT	mm	Projection			Seconn International Enterprise Co., Ltd.		
DRAWN	<i>Yi jialu</i>	SCALE	FREE	TITLE			
CHECK,BY	<i>Bao jianwei</i>	REV	A	HD15 F/2*DB9 F+2*RCA M+OPEN			
APP,BY	<i>Mr.Kuang</i>	DATE	2013/02/27	TOLERANCES			
DWG NO.	SE-S-0071			X.= ±	.X= ±	.XX= ±	.XXX= ±
PART NO.		SHEET	2/2	SIZE	A4		