

RoHS COMPLIANT

DESCRIPTION CONTROL			
REV	DESC	DATE	APP
A	FIRST RELEASE	2015/06/19	

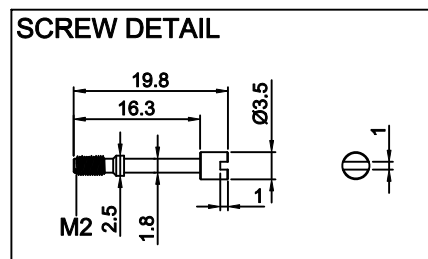

PIN ASSIGNMENT

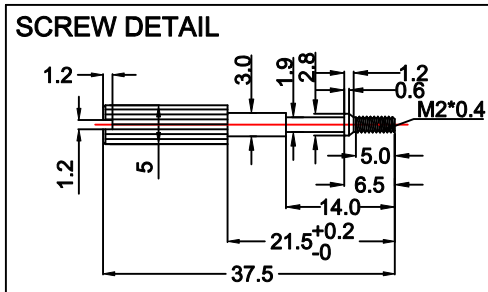
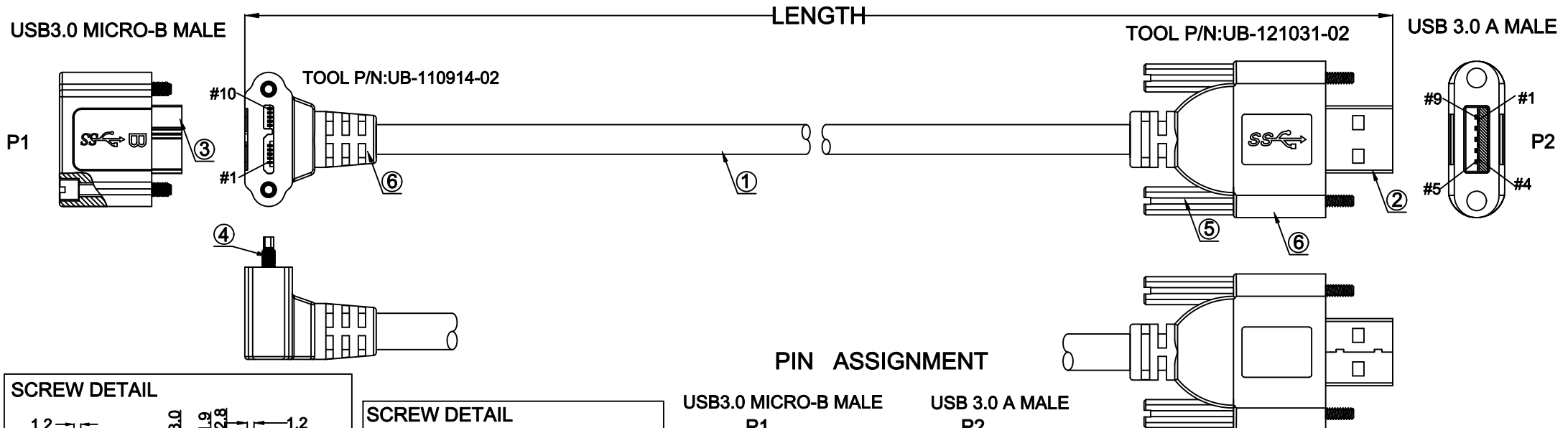
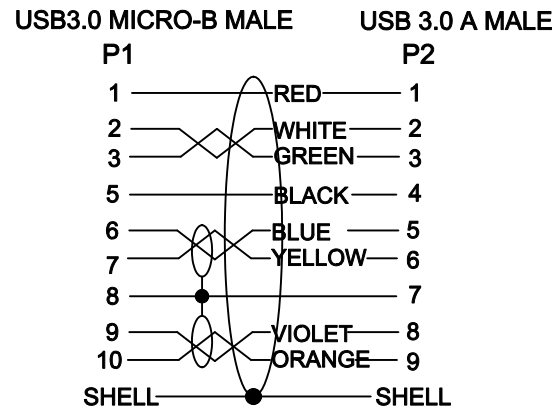

NOTES:
 1. PIN ASSIGNMENT SEE TO WIRE LIST.
 2. ELECTRICAL TEST CONDITION:
 (a). 100% OPEN, SHORT & MISWIRE TEST,
 (b). INSULATOR RESISTANCE: 20 Mohm MIN.
 DC 300V 0.01Sec.
 (c). CONTACT RESISTANCE: 3ohm MAX.

ITEM	QTY	PART NUMBER	DESCRIPTION
6		G0027	ALL CONNECTORS OVERMOLD VIOLET PVC.
5	2	C0428	SCREW:M2*0.4 Ø5*37.5MM NICKEL PLATED.
4	2	C0413	SCREW:M2 OD:3.5*19.8MM,NICKEL PLATED.
3	1	A0674	USB3.0 MICRO-B,MALE,BLUE INSULATTOR, SOLDER TYPE.
2	1	A0673	USB 3.0 A ,MALE,BLUE INSULATTOR,SOLDER TYPE.
1	1	E1003	(28AWG*1PAIR+D+AM+HM+SP+TEFLON)*2PCS+ 28AWG*1PAIR+24AWG*2C+F+AM+SP+TEFLON, OD:7.0MM,VIOLET PVC JACKET,UL2725.

UNIT	mm	Projection	Seconn International Enterprise Co., Ltd.
DRAWN	Deng zhifei	SCALE	FREE
CHECK, BY	Bao jianwei	REV	A
APP, BY	Mr. huang	DATE	2015/06/19
DWG NO.	SE-S-0211		X.= ± .X= ± .XX= ± .XXX= ±
PART NO.	SHEET	1/1	SIZE A4