

型号	模号
DB9外	
DB9内	
螺丝模	

DESCRIPTION	DATE	REV
Modify Packing Method	20180827	A1
Modify USB AM Mold	20201130	A2

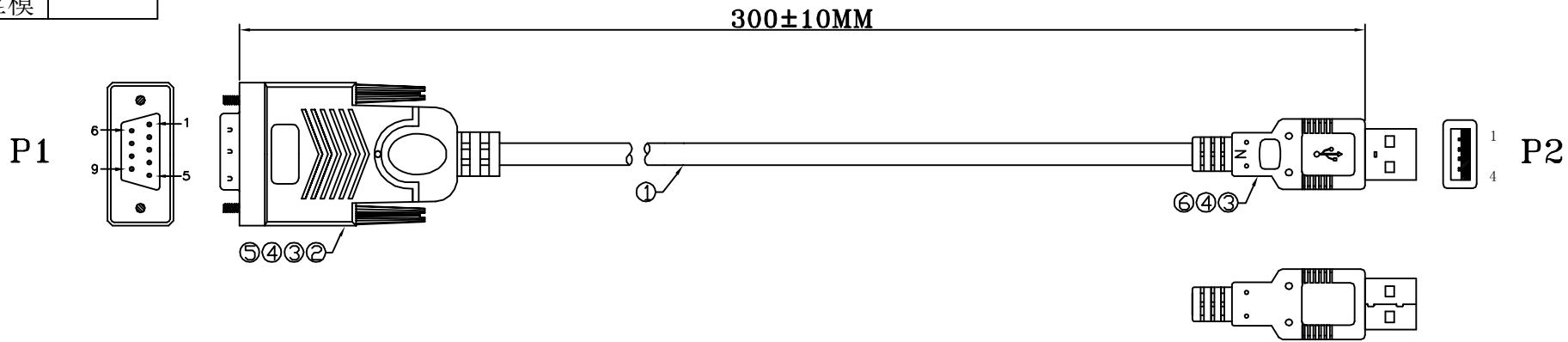

PACKING: ZIPLOCK BAG
1 PCS / BAG

PIN OUT

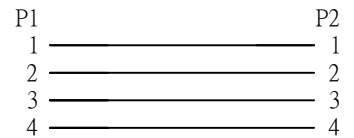

- ELECTRONIC TEST:
1. 100% TEST,(Open, Short, Miss Wire).
 2. Contact Resistance: 5Ω/ max.
 3. Insulation Resistance: 10MΩ /min.
 4. Hi-Pot: 300V /0.01s.
 5. Support Windows 10, 8, 7 and XP

PART LIST: ALL "ROHS" COMPLIANT, ALL MATERIALS ARE EQUIVALENT.

		1	PCS
6	USB AM:GOLD G/F" FLASH CONNECTOR, NICKEL PLAIED SHELL,PLASTLC:WHITE.	1	PCS
5	THUMB SCREW:#4-40 T4.0*40 P TYPE BLACK(黑色).	2	PCS
4	OUTER MOLD:PVC 45P BLACK(黑色).		KG/K
3	INNER MOLD:PE.		KG/K
2	CONN.:D-SUB 9P M PIN NICKEL PLATED INSULATOR BLUE SHELL NICKEL PLATED.+IC 板	1	SET
1	CABLE: NO UL 28AWG*4C COLOR : BLACK OD:4.5MM L=300MM.	0.3	M
ITEM	STANDARD SPECIFICATION	Q' TY	UNIT

Se Seconn International Enterprise Co., Ltd.

TOLERANCES		PROJECTION	TITLE				
AS DRAWING			D-SUB 9 PIN MALE TO USB AM RS232				
			CABLE BLACK L=300MM				
DRAWN	DIANA	DATE	PART NO.	SC-S-1808-0904			
SCALE		SIZE	A4	SHEET	1/1	REV	A2