

RoHS COMPLIANT

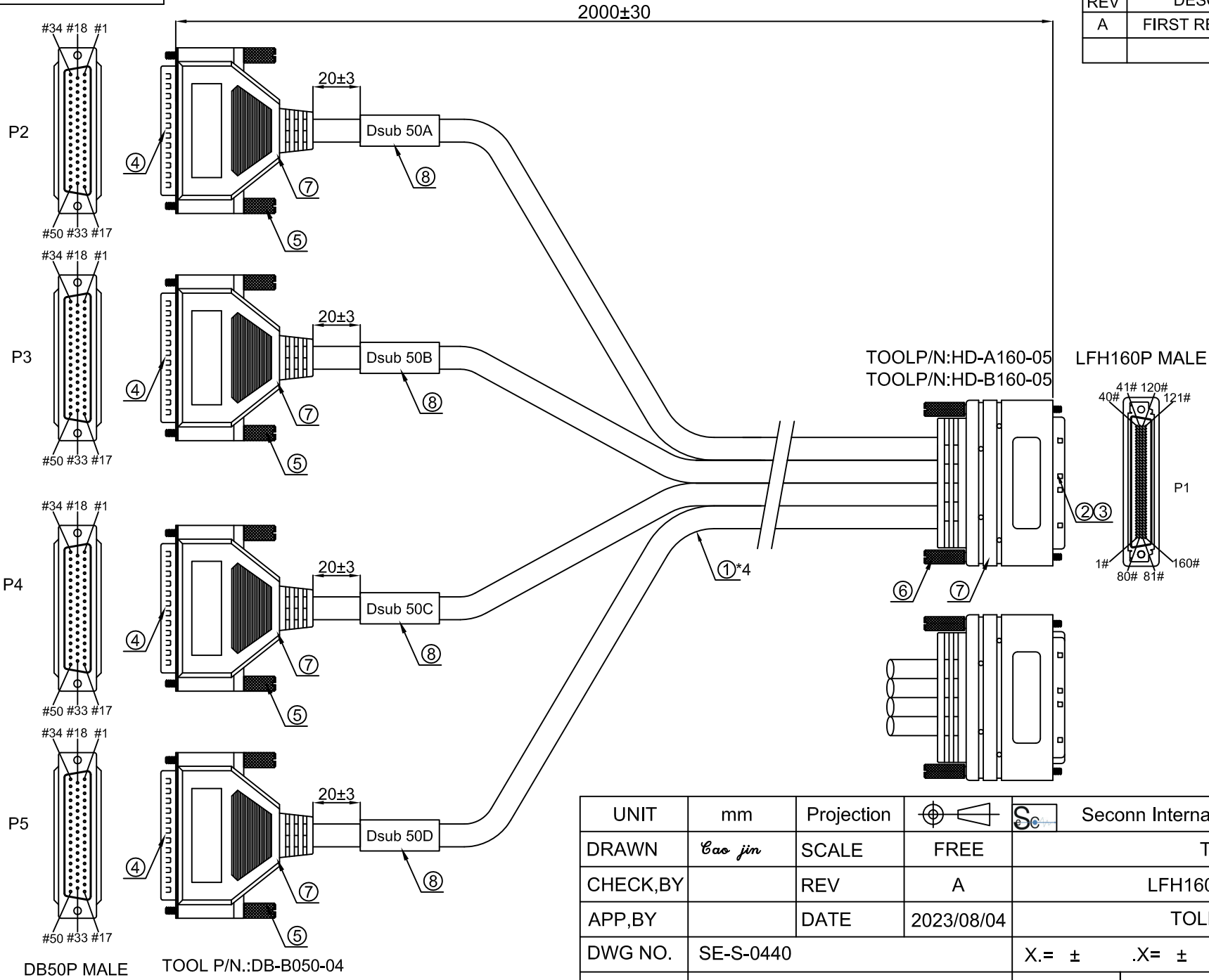

DESCRIPTION CONTROL			
REV	DESC	DATE	APP
A	FIRST RELEASE	2023/08/04	

TOOLP/N:HD-A160-05
TOOLP/N:HD-B160-05

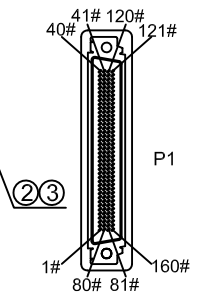

UNIT	mm	Projection			Seconn International Enterprise Co., Ltd.			
DRAWN	<i>Cao jin</i>	SCALE	FREE	TITLE				
CHECK, BY		REV	A	LFH160 M/4*DB50 M				
APP, BY		DATE	2023/08/04	TOLERANCES				
DWG NO.	SE-S-0440			X.= ±	.X= ±	.XX= ±	.XXX= ±	
PART NO.	SE-S-0440-2M			SHEET	1/2	SIZE	A4	

DB50P MALE TOOL P/N.:DB-B050-04

RoHS COMPLIANT

PIN ASSIGNMENT

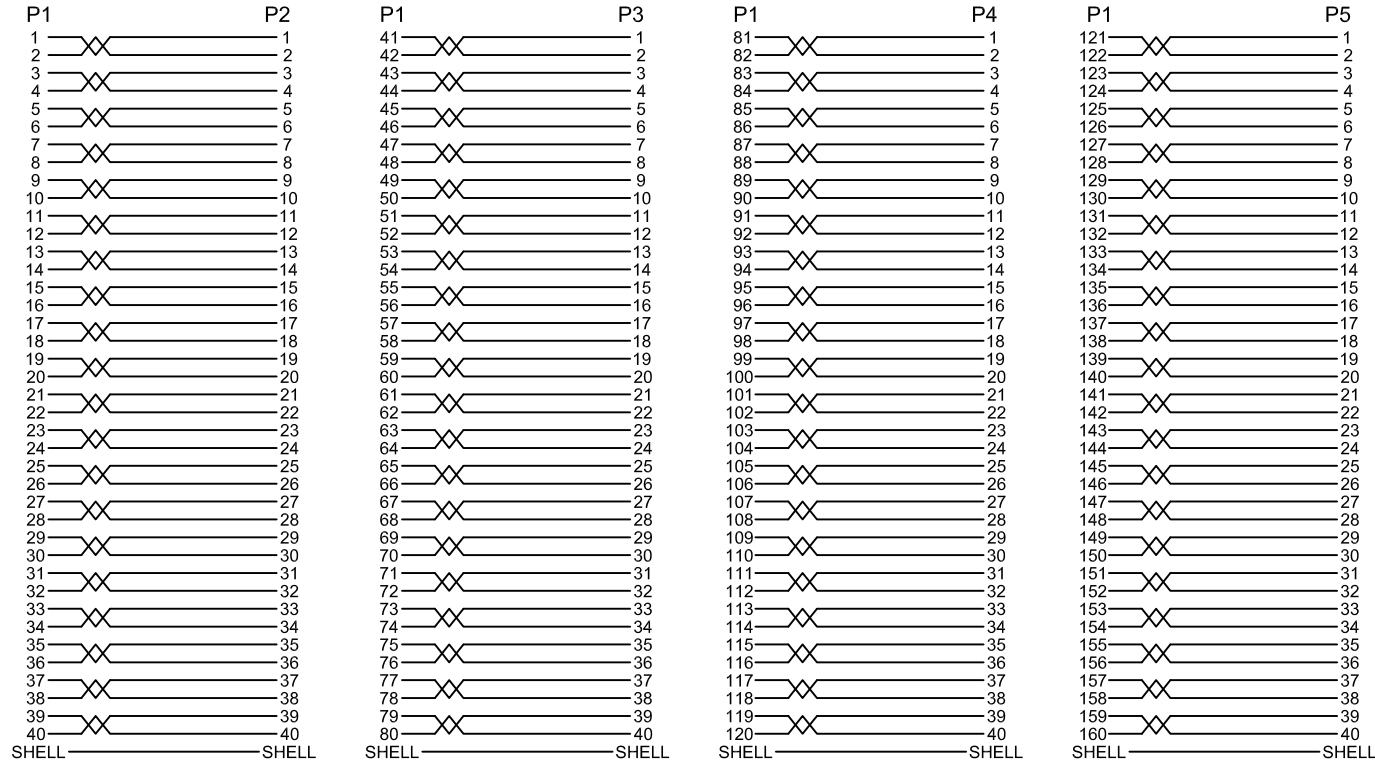

DESCRIPTION CONTROL			
REV	DESC	DATE	APP
A	FIRST RELEASE	2023/08/04	

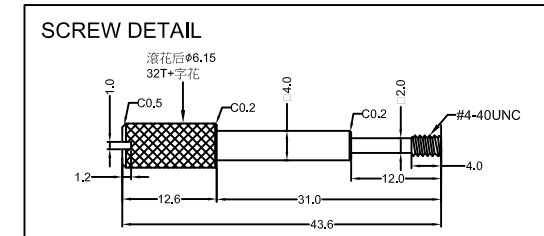
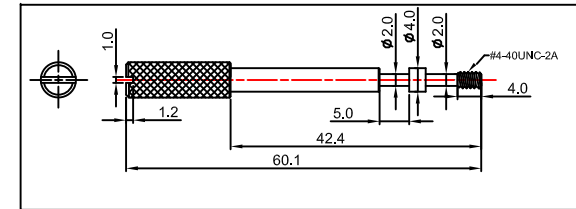

NOTES:

- PIN ASSIGNMENT SEE TO WIRE LIST.
- ELECTRICAL TEST CONDITION:
 - 100% OPEN, SHORT & MISWIRE TEST,
 - INSULATOR RESISTANCE: 20 Mohm MIN. DC 300V 0.01sec,
 - CONTACT RESISTANCE: 3 ohm MAX.

8	4		CABLE LABEL.
7		G0001	ALL CONNECTORS OVERMOLD BLACK PVC.
6	2	C0237	SCREW:#4-40UNC 5.2*60.1MM NICKEL PLATED.
5	8	C0088	SCREW:#4-40UNC 6.2*43.6MM NICKL PLATED.
4	4	A0316	DB50P MALE, BLACK INSULATOR, SOLDER TYPE.
3	4	B0716	CONN D-SUB PIN 28-36AWG PCB GOLD.(MOLEX:51-25-1020)
2	1	A1043	LFH160 MALE.(MOLEX:71624-3000).
1	4	E0574	28AWG*25P+ADB OD8.0MM BLACK PVC JACKET UL20276
ITEM	QTY	PART NUMBER	DESCRIPTION

UNIT	mm	Projection			Secon International Enterprise Co., Ltd.
DRAWN	Bao jin	SCALE	FREE	TITLE	
CHECK, BY		REV	A	LFH160 M/4*DB50 M	
APP, BY		DATE	2023/08/04	TOLERANCES	
DWG NO.	SE-S-0440			X.= ±	.X= ±
PART NO.	SE-S-0440-2M			.XX= ±	.XXX= ±
SHEET	2/2	SIZE	A4		